

HEAVY DUTY POLYOLEFIN CASTER ROLLER BEARING

APPLICATIONS:

Economical and light weight, non-marking floor protection, high shock/impact resistance, abrasion and chemical resistance.

SPECIFICATIONS:

SWIVEL:	Two rows of ball bearings in hardened raceways.
FORK:	1/4" formed steel plate, double welded.
KING PIN:	3/4" heat treated bolt and nut.
LUBRICATION:	Zerk in swivel raceway, wheel hub or lube axle.
AXLE:	1/2" Diameter bolt and nut.
FINISH:	Zinc Plated.

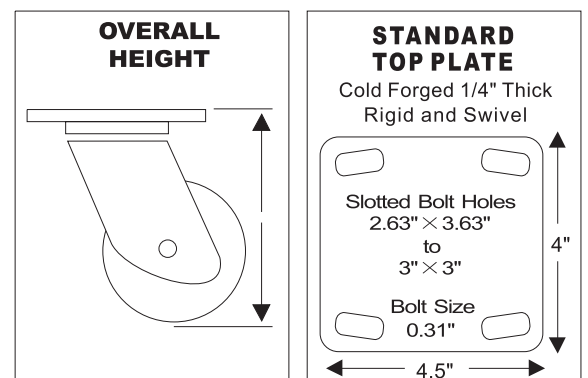

Part #	Description	Packing (PC)	Overall Height (inches)	Weight (LB)	Capacity (LB)
S6×2PO	6"×2" Polyolefin Swivel	330	7 1/2	4 3/4	1,100
R6×2PO	6"×2" Polyolefin Rigid	330	7 1/2	4	1,100
S8×2PO	8"×2" Polyolefin Swivel	300	9 1/2	5 1/2	1,200
R8×2PO	8"×2" Polyolefin Rigid	300	9 1/2	4 1/2	1,200
S5×2PO	5"×2" Polyolefin Swivel	350	6 1/2	5	900
R5×2PO	5"×2" Polyolefin Rigid	350	6 1/2	3 3/4	900
S4×2PO	4"×2" Polyolefin Swivel	400	5 1/2	4	800
R4×2PO	4"×2" Polyolefin Rigid	400	5 1/2	3	800

